

# SPEED QUEEN MULTI-HOUSING

QUANTUM® GOLD COIN DROP INSTALLED, PREP FOR COIN, PREP FOR CARD

## COMMERCIAL TOP LOAD WASHER

### Built for Reliable Performance

Speed Queen's top load washer, defined by its simplicity and its performance, provides everything you need to get the job done – and nothing you don't. Speed Queen's top load washer combines heavy-duty construction with reliable operation proven to stand the test of time. Speed Queen washers provide maximum energy efficiency and long-lasting performance.

- Touch pad control with sound annunciator
- 27 cycle selections
- Extract speed of 710 RPMs spins clothes out drier
- Integrated meter case
- Advanced suspension system
- Easy-to-read digital display
- Cycle programming flexibility
- Multi-level vend pricing
- Individual cycle modifier keys
- Durable stainless steel tub standard
- Wash Alert™ with Service Alert capable
- 3.26 cu. ft. (92.3 liters) wash capacity
- Large capacity coin box standard



Cutting edge Quantum control system from Speed Queen gives you the freedom to manage laundry your way and the power to achieve unmatched levels of revenue. This revolutionary technology provides users with more cycle choices than ever, offers unprecedented options to help lower operating costs and incorporates tools and options to increase revenue.



SPECIFICATIONS

# COMMERCIAL TOP LOAD WASHER

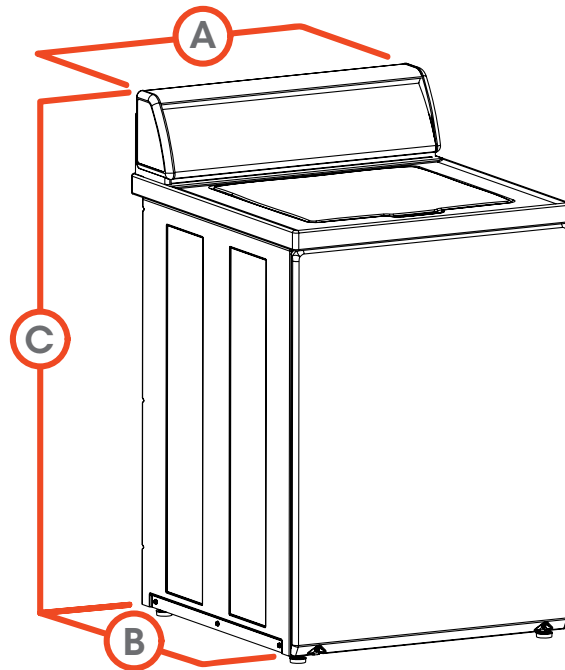
MODEL - see below for all models and activation available	
CONTROL OPTION	Quantum Gold
COLOR	White
CAPACITY - lb (kg)	16 (7.3)
OVERALL WIDTH - in (mm)	25.625 (651)
OVERALL DEPTH - in (mm)	28 (711)
OVERALL HEIGHT - in (mm)	43 (1092)
CYLINDER VOLUME - cu. ft. (liters)	3.26 (92.3)
SPIN SPEED G-FORCE (RPM)	710 (150)
MOTOR SIZE - HP (kw)	.5 (0.37)
WATER CONSUMPTION PER CYCLE - g (liter)	24.6 (93.0)
WF (WATER FACTOR) - gal/ft³ (liters/liter/cycle)	7.9 (1.06)
MEF (Modified Energy Factor) ft³/kWh/cycle (Liters/kWh/cycle)	1.69 (47.89)
AVAILABLE WATER TEMPERATURES	Hot, Warm, Cold
AVAILABLE CYCLES	Light, Medium, Heavy, Small Load, Normal, Perm Press, Delicate
WATER PRESSURE - p.s.i. (bar)	20-120 (1.4/8.3)
DRAIN	Pump
CYLINDER FINISH	Stainless Steel
NET WEIGHT - lb (kg)	206 (93.4)
SHIPPING WEIGHT - lb (kg)	218 (98.8)
SHIPPING DIMENSIONS APPROX. - in (mm)	Width 28 (711)
	Depth 30 (762)
	Height 45 (1143)
AGENCY APPROVALS	cULus



A. OVERALL WIDTH - in (mm)	25.625 (651)
B. OVERALL DEPTH - in (mm)	28 (711)
C. OVERALL HEIGHT - in (mm)	43 (1092)

MODELS	ACTIVATION
SWNNC2SP113TW02	Coin Drop Installed 
SWNNX2SP113TW02	Prep for Coin 
SWNNY2SP113TW01	Prep for Card 

For the most accurate information, the installation guide should be used for all design and construction purposes. Due to continuous product improvements, design and specifications subject to change without notice. The quality management system of Alliance Laundry Systems' Ripon facility has been registered to ISO 9001:2000.